



**YAMoRC**<sup>®</sup>  
DIGITAL

# YD6016LN CURRENT SENSOR

## 16-FOLD FEEDBACK MODULE

### QUICK STAR

(2022-09-20)

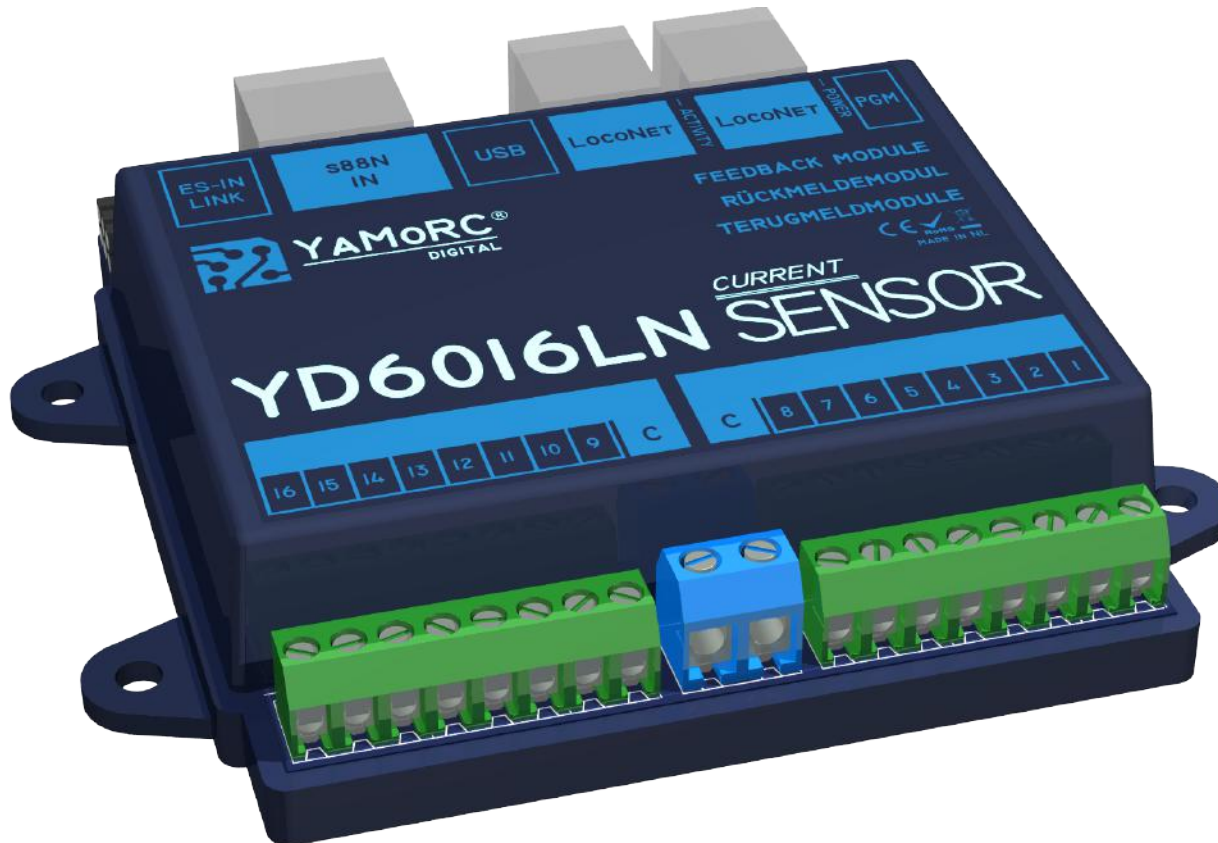

Designed by Karst Drenth  
Made in Germany  
Assembled in NL

**Contents**

Beschreibung..... 3

Description..... 4

Mounting, dimensional drawing ..... 4

Important notes (including Health & Safety)..... 5

*Must read before using Y6016LN*

Product/Hardware overview ..... 6

Connection example of the feedback unit at the 2-wire track  
and on the LocoNet<sup>®</sup>..... 7

Connection example extension of the YD6016LN via "ES-Link"  
and "s88N"..... 8

Configuring the feedback addresses and the total  
number of the feedback devices..... 9

Use the YD6016LN-CS to configure the switching decoder of  
the YD8xxx series..... 11

Connection of the switching decoders of the YD8xxx series via the  
"ES-Link to the YD6016LN-CS and what to consider..... 11

Firmware update of the switching decoders of the YD8xxx series via  
"ES-Link" with the YD6016LN-CS..... 12

Warranty ..... 13

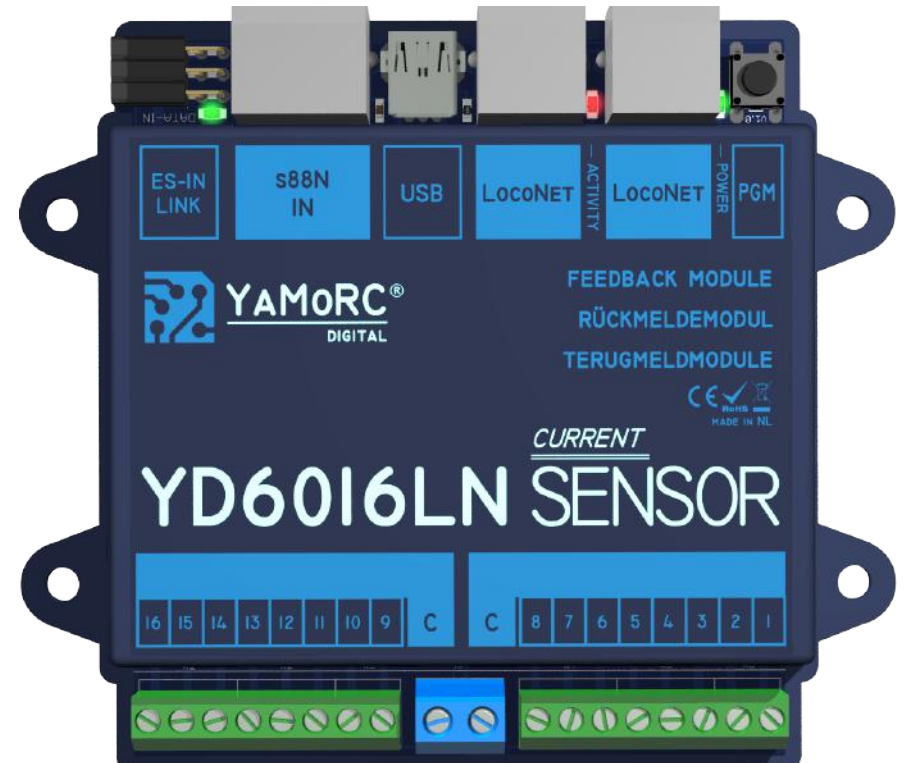

## Description

- The **YD61016LN-CS** has sixteen feedback inputs. These are divided into two groups with eight inputs. The feedback inputs of the YD6016LN-CS operate according to the current sensor principle and thus detect a load. The sensitivity of the feedback inputs is 1 mA current consumption.
- The **YD6016LN-CS** has a capacitive input filter at each feedback input. This filter suppresses noise (antenna effect) in the case of long long line distances and sections. This effectively suppresses false alarms.
- The configuration of the feedback addresses is done **simply** by pressing the programming button. We have deliberately decided to keep the configuration as simple as possible. For this reason, **no further settings** on the YD6016LN-CS are necessary for normal operation. Only a freely selectable feedback address must be assigned as start address. The YD6016LN-CS then automatically occupies fifteen subsequent feedback addresses.
- The **YD6016LN-CS** is delivered with the LocoNet® feedback addresses 1-16 preassigned.
- The firmware of the **YD6116LN-CS** can be updated at any time via the USB port. In addition, it is possible to adjust various settings with the configuration tool.  
Each feedback input can be assigned an individual feedback address, an individual switch-on and switch-off delay and an action be assigned. The feedback addresses can be freely assigned in the address range between 1 and 4096. By entering a switch-on or switch-off delay, the flickering of the feedback is effectively prevented.
- The connection to the LocoNet® is made either via LocoNet® B or T. Attention! LocoNet® T and B must never be connected to each other.
- Via the "s88N-IN" connection, the YD6016LN-CS can be extended by a further five s88N modules with 16 feedback inputs. This creates a single LocoNet® module with 96 feedback inputs. Attention! Simultaneous use of "s88N" and "ES-IN Link" is not permitted.
- Via the "ES-IN Link" connection, it is possible to expand the YD6016LN-CS by another five YD6016ES modules. This creates a single LocoNet® module with 96 detectors. Attention! Simultaneous use of "s88N-IN" and "ES-IN Link" is not permitted.
- The "ES-IN Link" connector allows to configure all other modules equipped with an "ES-PGM Link" connector.

### Technical Data

Number of feedback inputs	16 inputs (arranged in two groups of 8)
Address area	1 - 4096
Load capacity of a feedback input	2 A
Total load capacity of all feedback inputs	8 A
Overload resistance of a feedback input	5 A for 100 ms
Feedback sensitivity	1 mA Current flow
Housing Dimensions	84 mm x 88 mm x 22 mm
Distance Between Holes	94,5 mm, 42,5 mm

### Mounting

The YD6016LN-CS is mounted via the four mounting holes on the side of the housing.

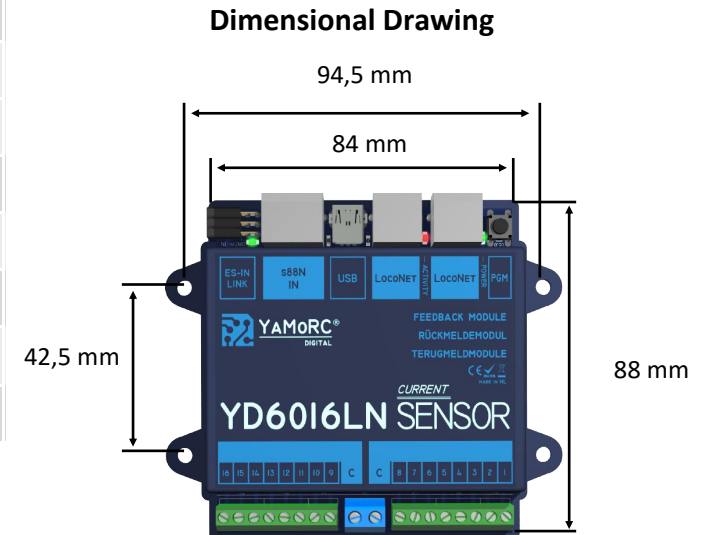

### Important Notes (Including Health & Safety):

- The YD6016LN-CS is intended exclusively for operation on an electric model railway.
- The YD6016LN-CS is **not** a toy and is therefore **not** suitable for children under 14 years of age.
- **Never** leave the YD6016LN-CS operating without your presence. Please disconnect the product before leaving it unattended.
- Voltage sources (power supplies, transformers, etc.) **must comply** with the current VDE/EN and CE standards.
- The voltage sources used (power supplies, transformers) **must comply** with Protection Class 2. Failure to comply may result in serious damage to the YD6016LN-CS . The voltage sources must be marked with this symbol (illustrated below).



Further information on the **Protection Class 2** can be found here: <https://www.xppower.com/resources/blog/iec-protection-classes-for-power-supplies>

- Voltage sources must **not** exceed a maximum output current of 3A.
- Voltage sources must be fused in such a way that a cable fire cannot occur in the event of a fault.
- A USB isolator is to be used if digital voltage of a digital command station is applied to the Power AC/DC connector of the YD8xxx modules or if a command station is connected to USB or LocoNet®. The USB isolator prevents dangerous ground loops or equalizing voltages or currents between the components.
- A common earth connection of different voltage sources or circuits is **not** permitted. This will destroy the YD6016LN-xx.
- Auf einen ausreichenden Verdrahtungsquerschnitt der einzelnen Anschlüssen ist unbedingt zu achten.
- The connection terminals for "C" are designed for a cross-section of 0.75 mm<sup>2</sup>. All other connection terminals are designed for a cross-section of 0.5 mm<sup>2</sup>.
- Connection work must always be carried out in a de-energised state. Disconnect or switch off power AC/DC and signal input.
- The YD8016LN-CS must **never** be installed near sources of intense heat, such as radiators or places exposed to direct sunlight. Therefore, install the YD6016LN-CS in a place with sufficient ventilation to be able to dissipate the waste heat.
- The YD6016LN-CS is designed for dry indoor use only. Therefore, do **not** operate the YD6016LN-CS outdoors or in environments with extreme fluctuations in temperature and humidity.
- Do **not** attempt to open the YD6016LN-CS . Improperly performed actions can lead to the destruction of the YD6016LN-CS .

## Hardwareübersicht

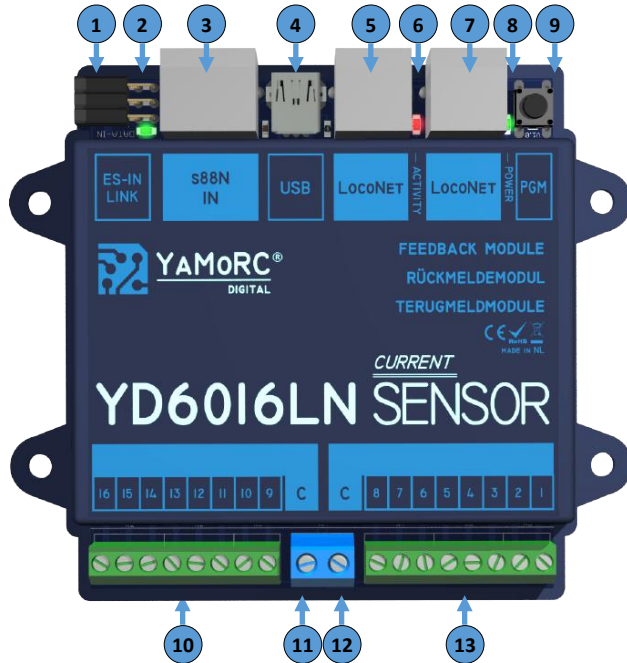

1	<b>ES-IN Link</b>	<b>Connection for further modules with "ES Link" functionality.</b> This connection enables modules that have an "ES-PGM Link" to be easily configured. Alternatively, five YD6016ES feedback modules with 16 inputs each can be connected. <b>Attention!</b> If the "ES-IN Link" is used to connect feedback modules, the "S88N-IN" must not be used at the same time.
2	<b>Green LED</b>	Display Configuration process via "ES Link" is running
3	<b>s88N -N</b>	At this connection another five "s88N" standard Feedback modules with 16 inputs can be connected. <b>Attention!</b> If the "s88N-IN" is used to connect feedback modules, the "ES-IN Link" must not be used at the same time.
4	<b>USB Anschluss</b>	
5	<b>LocoNet® Connection 1</b>	

6	<b>Red LED</b>	Load indicator of the feedback unit. The brighter the LED lights up, the higher the current detected by the feedback module.
7	<b>LocoNet® Connection 2</b>	
8	<b>Green LED</b>	LocoNet® and power supply available.
9	<b>Programming button</b>	
10	<b>1</b> : : : <b>8</b>	Connection feedback input no. 1  (1. Feedback group)  Connection feedback input no. 8
11	<b>C</b>	Common connection 1st feedback group
13	<b>C</b>	Common connection 2st feedback group
13	<b>9</b> : : : <b>16</b>	Connection feedback input no. 9  (2. Feedback group)  Connection feedback input no. 16

**Connection example of the feedback unit on the 2-wire track and on the LocoNet<sup>®</sup>**

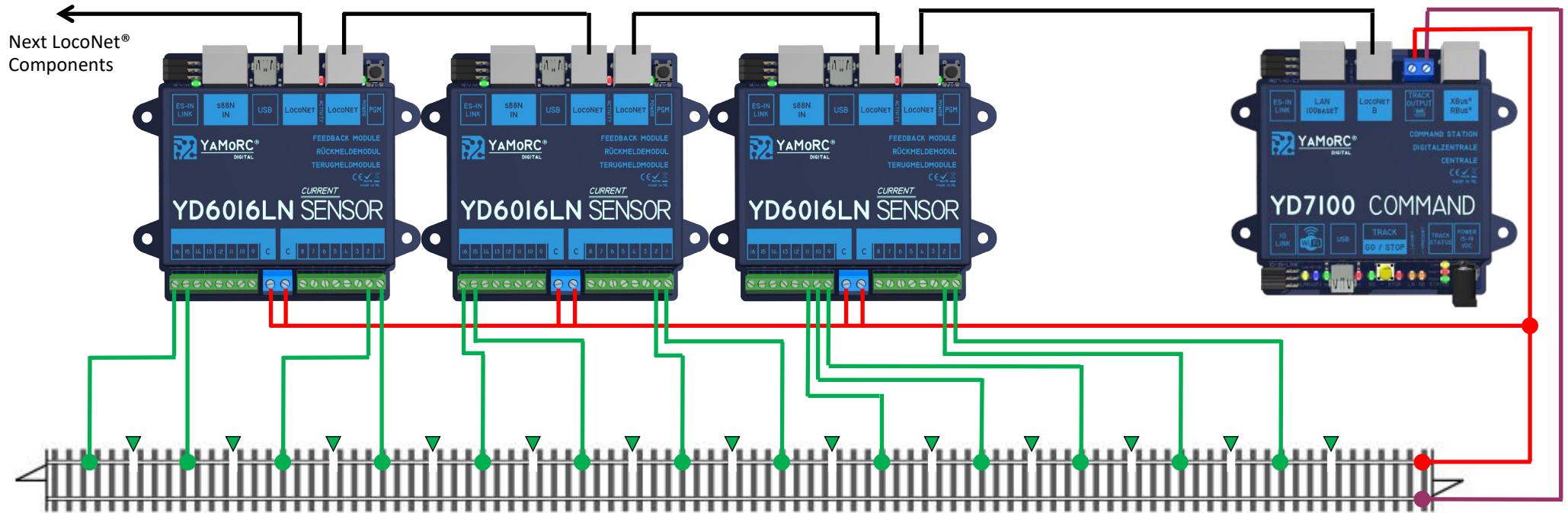

**Attention!**

All connection work on the YD6016LN-CS must always be carried out in a de-energised state. Disconnect the power supply from the mains and switched off!

## Connection of the YD6016LN-CS to the control centre via LocoNet<sup>®</sup> and expansion options via "ES-IN Link" and "s88N"

Next LocoNet<sup>®</sup>  
Components



Next LocoNet<sup>®</sup>  
Components

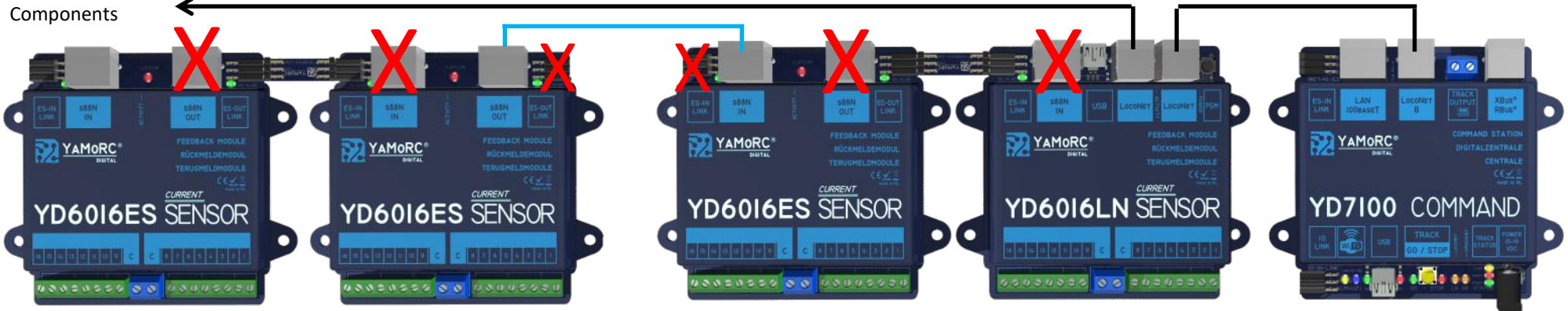

**Maximum extension:** 96 feedbacks, consisting of five feedback modules with 16 inputs each in the entire "ES-Link" line.

**Attention!** Joint use of "ES-OUT Link" and "s88N-OUT" or "ES-IN Link" and "s88N-IN" on the same module is not permitted.

### Attention!

All connection work on the YD6016LN-CS must always be carried out in a de-energised state. Disconnect the power supply from the mains and switched off!



## Configuring the feedback addresses and the total number of feedback devices of the YD6016LN-CS

YaMoRC has chosen to make the programming of the YD6016LN-CS as simple as possible. The YD6016LN-CS is preset "out of the box" with the LocoNet® feedback addresses 1-16. Of course, any other feedback address can also be assigned as the start feedback address. The start feedback address is assigned by switching the corresponding DCC turnout address via the turnout control panel of the command station used. In the same way, the YD6016LN-CS is informed how many feedback modules are present at the YD6016LN-CS. If no further feedback modules are connected via the "ES-IN Link" connection or the "s88N-IN" connection, the setting of the number of feedbacks can be omitted, as the YD6016-CS is already preassigned with the internal number of feedbacks (16 pieces).

If you have any questions, please contact our service department. We will certainly find a solution for you.

### Configuration of the start feedback address

1. Establish connection via LocoNet® to the control centre. 1

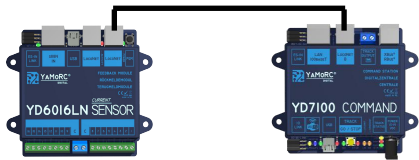

2. **Switch on the power supply to the control unit.**

3. **Press the programming button once to set the YD6016LN-CS to configuration mode for the start feedback address.** The green LED confirms that the YD6016LN-CS is in configuration mode for the start feedback address with the flashing sequence Flash, LED off, Flash, LED off (\*—\*—), etc. 2

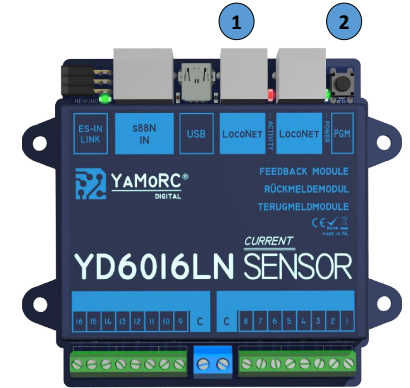

4. Call up the turnout control panel of the central unit and the turnout address (e.g. 17) to be assigned as the start feedback address. Do not carry out a switching operation yet! (For the exact procedure on how to call up a turnout control panel, please refer to the documentation of your control unit or app).
5. Press the desired turnout address (e.g. 17), which is to be used as the start feedback address, once at the turnout control panel of the central unit. The following fifteen feedback addresses (18-32) are automatically assigned. Thus, the YD6016LN-CS occupies sixteen consecutive feedback addresses (17-32). (For the exact procedure for switching a turnout address, please refer to the documentation of your control unit or app).

 If no further feedback modules are used on the YD6016LN-CS ("ES-Link", "s88N"), the configuration mode can be exited by pressing the programming button to exit configuration mode.

6. The assignment of the feedback addresses is completed and the YD6016LN-CS switches to configuration mode for the total number of feedback devices. Continue next page with item 7.

## Configure the total number of detectors of the YD6016LN-CS.

The total number of feedback units is calculated from the internal feedback units (16 units) of the YD6016LN-CS and the number of feedback units connected via the "ES-IN Link" or via "s88N".

Example: If two YD6016ES modules are connected to the YD6016LN-CS via "ES-IN Link", the number of individual feedback units must be added. (16+16+16=48 feedback units). The total number (48) must be communicated to the YD6016LN-CS by switching the corresponding DCC turnout address, as described here.

7. After the assignment of the start feedback address has been completed, the YD6016LN-CS automatically switches to the configuration mode for the total number of feedback units. The green LED confirms with the flashing sequence flash, flash, LED off, flash, flash, LED off (\*\*—\*\*—) etc. that the YD6016LN-CS is in configuration mode for the number of feedback units.
8. Call up the turnout control panel of the central unit and the calculated turnout address (48). Do not perform a switching operation yet!  
*(For the exact procedure on how to call up a turnout control panel, please refer to the documentation of your control unit or app).*
9. Press the calculated turnout address (48) once on the turnout control panel of the central unit.  
*(For the exact procedure for switching a turnout address, please refer to the documentation of your control unit or app).*
10. The assignment of the number of feedbacks is completed and the YD6016LN-CS automatically exits the configuration mode.

### Achtung!

Alle Anschlussarbeiten am YD6016LN-CS müssen immer im **spannungslosen** Zustand erfolgen. Spannungsversorgung vom Netz trennen und die Zentrale abschalten!

## Use the YD6016LN-CS to configure the switching decoders of the YD8xxx series.

The YD6016LN-CS can be used to configure the YD8008, YD8044 and YD8116 switching decoders. The configuration tool of the YD6016LN-CS can be used to adjust the settings of the switching decoders.

werden:

The following settings can be adjusted for the switching decoders of the YD8xxx series:

- Free assignment of the switching addresses
- Switching pulse duration for each output
- Address switching matrix and the inversion of the switching term
- Signal definitions can be selected and individually adjusted (YD8116)

## Connecting the switching decoders of the YD8xxx series via the "ES-Link" to the YD6016LN-CS and what to consider

- The power supply of the **YD8008**, **YD8044** and YD8116 (Power AC/DC) must **not** be connected to the Digital Central Unit and DCC (Track Out of the Central Unit).
- To test the settings, a separate voltage source AC or DC can be connected to "Power AC/DC" of the switching decoder.
- A connection via "S88N IN" must be disconnected.
- To prevent ground loops via USB, the YD6016LN-CS should always be connected to the PC or laptop via USB alone.
- The use of a USB isolator is recommended.
- The YD6016LN-CS is connected via "ES-IN Link" and the "ES-PGM Link" socket on the YD8xxx. The connection can be made either via the YD6901ES-LINK or the YD6902ES-EXT connection set.

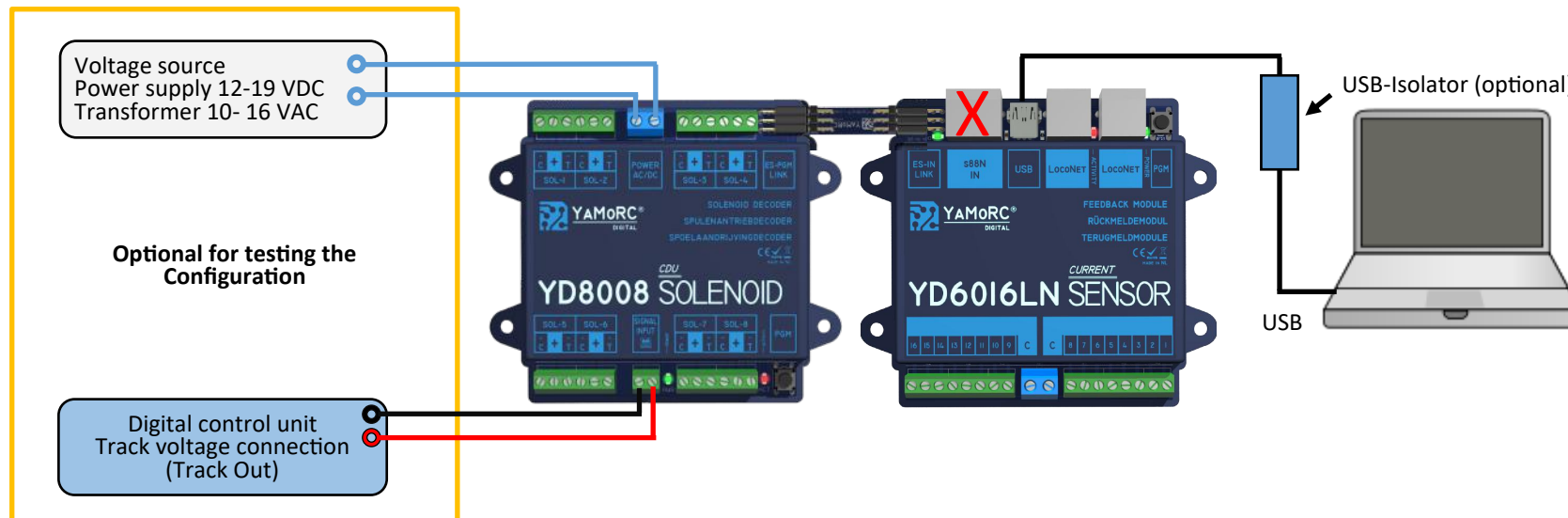

## Firmware update of the switching decoder of the YD8xxx series via "ES-Link" with the YD6016LN-CS

- The power supply to the **YD8008**, **YD8044** and **YD8116** via the "Power AC/DC" terminals and the "Signal Input" (Track Out of the control unit) must be **disconnected** before the firmware update.
- The LocoNet® connection on both LocoNet® sockets of the YD6016 must also be disconnected.
- A connection via "S88N IN" must also be disconnected.
- To prevent ground loops via USB, the YD6016LN-CS should always be connected to the PC or laptop via USB alone.
- The YD6016LN-CS is connected via "ES-IN Link" and the "ES-PGM Link" socket on the YD8xxx. The connection can be made either via the YD6901ES-LINK or the YD6902ES-EXT connection set.



## Warranty

### 24 months warranty from date of purchase

Dear Customer,

Congratulations on your purchase from YaMoRC. YaMoRC's high quality products have been manufactured using modern manufacturing processes and have been subjected to careful quality control and tests.

Therefore, when purchasing a YaMoRC product, the company YaMoRC grants you a manufacturer's warranty of 24 months from the date of purchase in addition to the national warranty rights to which you may be legally entitled to, from your YaMoRC specialist dealer as contractual partner.

### Warranty conditions:

This warranty applies to all YaMoRC products purchased from a YaMoRC dealer. Warranty services are only provided if proof of purchase is presented. Proof of purchase is the purchase receipt from the YaMoRC specialist dealer. It is therefore recommended to keep your purchase receipt safe.

### Content of the guarantee/exclusions:

The warranty includes, at YaMoRC's discretion, the free repair or free replacement of the defective part, which can be proven to be due to design, manufacturing, material or transport faults. For this purpose, you must send the decoder to us properly stamped. Further claims are excluded.

### The warranty claims are void:

1. in the case of general wear and tear at expected locations (e.g. screw terminals).
2. in the case of modification of YaMoRC products with parts not approved by the manufacturer.
3. in the case of modification of parts, especially by opening the housing.
4. if the product is used for purposes other than those intended by the manufacturer.
5. if the instructions given by YaMoRC in the operating manual have not been thoroughly read by the user & risked mis-use of the product.

The warranty period is not extended by repair or replacement.

Warranty claims can be made either to your dealer or by sending the claimed product directly to YaMoRC together with the warranty certificate, proof of purchase and description of the defect.



### **Drenth Design & Consulting B.V.**

Glazeniershorst 209  
NL-7328 TJ APELDOORN

**Liability:** Drenth Design & Consulting B.V.

**Phone:** +31643392605

**E-Mail:** ddc@yamorc.com

**Directors:** Gabriele Drenth-Viertel, Karst Drenth

**Trade register:** 72184728

**VAT No/Tax ID:** NL-859019901B01